



SPECIFICATIONS FOR COMPETITION EQUIPMENT

CROSS-COUNTRY, SKI JUMPING, NORDIC COMBINED

EDITION 2023/2024

INTERNATIONAL SKI AND SNOWBOARD FEDERATION

Blochstrasse 2; CH- 3653 Oberhofen / Thunersee; Switzerland

Telephone: +41 (33) 244 61 62

Fax: +41 (33) 244 61 71

E-mail: nordics@fisski.com for CC/ JP/ NC

Website: www.fis-ski.com

Oberhofen, June 2023

TABLE OF CONTENTS

Specifications for Competition Equipment Cross-Country, Ski Jumping, Nordic Combined.....	5
A. Definition.....	5
1. Competition Equipment.....	5
2. Procedures for the Acceptance of New Developments in Competition Equipment.....	6
B. Cross-Country Skiing Competition Equipment.....	8
1. General Rules.....	8
2. Cross-Country Racing Skis.....	8
3. Cross-Country Racing Bindings.....	9
4. Cross-Country Racing Boots.....	9
5. Cross-Country Racing Poles.....	9
C. Ski Jumping Competition Equipment.....	11
1. Jumping Skis.....	11
2. Jumping Ski Bindings.....	13
3. Ski Jumping Boots.....	13
4. Ski Jumping Suits.....	14
5. Crash Helmets.....	18
6. Ski Goggles.....	19
7. Ski Gloves.....	19
D. Bibs.....	19
1. FIS Specifications for Cross-Country Starting Bibs.....	19
2. FIS Specifications for Ski Jumping Starting Bibs.....	20

Specifications for Competition Equipment Cross-Country, Ski Jumping, Nordic Combined

A. Definition

General Principles

The FIS Council shall be the sole authority for determine whether the use of a name, designation, trademark, logo or any other distinguishing sign complies with the FIS Rules and Guidelines; and

The FIS reserves the right to further interpret and/or supplement these Rules and Guidelines in order to help ensure that their spirit and purpose are respected.

1. Competition Equipment

The term “competition equipment“ implies all items of equipment used by athletes in competitive skiing, including clothing and implements that serve a technical function. The entire competition equipment forms a functional unit. In this connection the following points must be observed:

- a) The principle of safety
- b) The principle of fairness

1.1 Effective manufacturer

“Effective Manufacturer” means the enterprise which itself manufactures the Competition Equipment and/or effectively controls and manages the manufacturing of the Competition Equipment under its own responsibility through customary subcontracting processes, and whose Competition Equipment is effectively offered on the market to end users. If requested by FIS, the manufacturer shall provide documentary evidence of such commercial activities at retail level (such as manufacturing activity in the market of the relevant Competition Equipment, including control over the manufacturing process, retail activity and marketing expenditures linking the brand to the relevant piece of equipment) as a condition for the commercial markings to be accepted as a Manufacturer’s Identification as further defined in these Specifications.

1.2 Manufacturer’s identification

“Manufacturer’s Identification” means the trade name, brand, logo, or other designation of the Effective Manufacturer under which the particular Competition Equipment is manufactured and commercially offered to the market.

The Manufacturer’s Identification must be a sports equipment brand, which means that the Manufacturer’s Identification is principally used for Competition Equipment and is not principally used for non-sports equipment, and/or cannot be confused with a similar or identical article used in another line of business, unrelated to Competition Equipment.

1.3 Competition implements

Competition implements refer to equipment which fulfil essential functions during the competition but which can be separated from the actual competition.

Examples: skis, bindings, boots, poles, clothing, helmets, ski goggles.

1.4 Additional equipment (accessories)

Additional competition equipment (accessories) are those components or implements which exert an influence on the technical function of the competition equipment and which are attached directly to the equipment by means of recognised fastenings. Such accessories do not perform essential functions during the competition.

Example: parablacks, plastic tip covers, additional weights, back protectors.

1.5 Auxiliary equipment

Auxiliary equipment refers to those components of the competition equipment which do not fulfil an essential function, and which do not fall under the heading of additional equipment

Example: measuring instruments.

2. Procedures for the Acceptance of New Developments in Competition Equipment

Article 222.4 of the ICR reads as follows:

New developments must be submitted by 1st May, at the latest, for the following season. During the first year new developments can only be approved provisionally for the following season and must be finally confirmed prior to the subsequent competition season.

2.1 Eligible applicants

- a) Manufactures or distributors of the innovation
- b) National Ski Associations
- c) Members of the Committee for Competition Equipment

The FIS Technical representative from each FIS Committee is eligible to submit applications only for new developments to the Committee for Competition Equipment. Manufacturers, distributors and National Ski Associations have to submit their applications to the respective FIS Technical Committee in advance to be decided whether the item is a new development or a further development of an existing product.

2.2 Items for application

Any significant new developments which are to be used as equipment in competitive skiing, may be submitted for acceptance. It is solely the responsibility of the Committee for Competition Equipment to decide whether a new development conforms to the FIS „Competition Equipment Specifications“ taking into consideration the medical, legal and safety standpoints. The Committee can at any time, however, arrange the removal of an application with regard to items of equipment to be used in competition sport, in accordance with the decisions of these guidelines.

2.3 Prototype, samples

The application must include a detailed description of the innovation. A prototype or sample must be submitted with the application. Relevant reports by scientific

experts, as well as reports of experiences made by trainers or participants are to be submitted.

2.4 Decisions of the Committee for Competition Equipment

The Committee for Competition Equipment deals with these applications at its next meeting. If the Committee is of the opinion that the item being presented conforms fully to the valid Specifications for Competition Equipment, this decision will be recorded in a relevant decision.

If the Committee reaches the conclusion that the innovation could be accepted in accordance with the relevant principles and decisions of the FIS Specifications for Competition Equipment in competition sports, the innovation can be provisionally approved for testing for the duration of the following season.

This approval can, however, also be conditionally accepted. On the grounds of fairness, exceptions can be made for certain competitions (Olympic Winter Games, World Championships, etc.).

However, the Committee for Competition Equipment can also take the following measures before provisional approval. These can be dealt with individually or together:

- a) Requesting further information from the FIS Technical Committees, such as reports by experts and technical data.
- b) Seeking reactions from the FIS Technical Committees. These opinions must be submitted in writing and take the following factors into consideration:
 1. Explanation with regard to the usefulness and necessity of the new developments
 2. Opinions with regard to the safety of the new developments
3. Assurance that in accepting the new developments, the principle of fairness will be guaranteed.c) Soliciting reports by experts and further information through the Committee for Competition Equipment itself. Should the new developments not conform to the principles of the FIS Specifications for Competition Equipment, either through the application itself, or during the course of the procedures, the use of the new developments in question will be banned in competition sport. This will also occur if, during the item's probation period, circumstances result which lead the Committee to decide that the new developments do not conform to the principles of the FIS Specifications for Competition Equipment. In such a case, the provisional approval will be rescinded, with immediate effect.

2.5 Proposals to the FIS Council

Changes in the Specifications for Competition Equipment can be proposed to the FIS Council only through the Committee for Competition Equipment - either by means of an initiative from the Committee itself or through an application of one of the National Ski Associations or Technical Committees to the Committee for Competition Equipment.

B. Cross-Country Skiing Competition Equipment

1. General Rules

The following rules apply to all type of Cross-Country competition equipment such as skis, bindings, boots, poles and any additional equipment.

1.1 Restrictions

No equipment is permitted which:

- a) Affect the natural push-off movement of competitors' feet and arms or those that enhance it (such as spring devices or other mechanisms in skis, poles, binding or boots).
- b) Makes use of energy not originating from the competitor, such as artificial heating devices, chemical energy accumulators, electric batteries, mechanical aids, etc.).
- c) Affect the external conditions of the competition to the detriment of other competitors, such as changing the track or snow conditions.
- d) Increase the risk of injury to competitors and other persons who are authorized to be present at the competition venue, when used normally.

1.2 Procedure and collaboration with IBU

Any new developments in equipment produced by the industry or the NSAs for the following season must be submitted to the FIS & IBU no later than the 1st of May of the year in which the season begins.

The submission must be accompanied by appropriate information material such as drawings, descriptions or test results.

Prototypes must be submitted without exception. New developments that are in compliance with the rules will be immediately approved by the FIS & IBU.

IBU and FIS shall update each other about prototypes for equipment used in both Federations' sports to ensure the same allowance process.

2. Cross-Country Racing Skis

2.1 Definition

The Cross-Country racing ski is a type of ski, whose features guarantee the best possible application of the gliding techniques to master Cross-Country pistes (uphills, bumpy terrain, downhills). The basic features of this type of ski are defined in these rules.

2.2 Restrictions

Cross-Country racing skis must have the same basic geometric features (ski width, overall height, height of the tail and height of the tip) than cross-skiing skis commercially available with the following restrictions:

2.2.1 Ski length

Minimum: height of skier minus 100 mm

2.2.2 Same construction

Both skis must be constructed in the same way and must be the same length.

2.2.3 *Mass*

Skis must weigh at least 750 g per pair (without bindings). No limitations with regard to the distribution of mass.

2.2.4 *Running surface*

The entire width of the running surface can be smooth or slightly grooved length-wise. With the exception of the running groove, however, the level must be constant in the entire length and width. Climbing aids in the form of scale patterns or step patterns are permitted. Devices that are activated by any energy other than the competitor's own muscular power are not permitted.

2.2.5 *Edges*

The edges must not face up and outwards, making the running surface narrower than the top surface (no wedge shape).

3. **Cross-Country Racing Bindings**

As commercially available. No limitations with regard to material and make, subject to the restrictions described at article 1.

4. **Cross-Country Racing Boots**

As commercially available. No limitations with regard to material and make, subject to the restrictions described at article 1.

5. **Cross-Country Racing Poles**

5.1 **Definition**

The Cross-Country racing pole is a pole, whose features guarantee the best possible application of the gliding techniques to master Cross-Country pistes (uphills, bumpy terrain, downhills).

5.2 **General rules**

5.2.1 *Poles of equal length*

Two poles of equal length must be used in competition, with one pole held in each hand.

5.2.2 *Pole length*

The maximum pole length must not exceed the competitor's height, nor measure below the hips (measurements are taken by placing the tip of the pole on the ski in front of the binding)

In classical technique competitions, the maximum pole length must not exceed 83% of the competitor's body height. In free technique competitions, the maximum pole length must not exceed 100% of the competitor's height. The body height is measured with ski boots on from a flat surface, to the top of the uncovered head.

The pole length is measured from the bottom of the pole to the highest attachment of the strap.

All measurements will be rounded to the nearest centimetre as follows: less than 0.5 cm will be rounded down and 0.5 cm and above will be rounded up.

5.2.3 *Constant length*

The pole must have a constant length. It may not, for example, possess a telescopic system.

5.2.4 *Foreign energy*

The pole must not create a foreign energy to favour push-off (e.g. springs or mechanical devices).

5.2.5 *Weight*

No limitations regarding the weight of the pole.

5.2.6 *Construction*

The poles may be constructed asymmetrically (e.g. there may be a difference between left- and right-hand poles).

5.3 **Technical Specifications**

5.3.1 *Grip*

The grip must be attached to the shaft. There are no limitations with regard to geometric features or material.

5.3.2 *Straps*

The straps must be joined to the grip or the shaft. They may be adjustable in length and width.

5.3.3 *Shaft*

There are no limitations with regard to material and make of the shaft or distribution of mass.

5.3.4 *Baskets*

Baskets with varying geometric features and materials are permitted to master various snow conditions. The baskets, however, must not change the condition of the track, so that other competitors suffer disadvantages.

5.3.5 *Tip*

Tips may be joined to the shaft at any angle. It is permitted to use one or more tips per pole. There are no limitations with regard to material.

C. Ski Jumping Competition Equipment

1. Jumping Skis

1.1 Definition

Jumping Skis are manufactured especially for use on Ski Jumping hills. Their construction is adapted to the requirements of Ski Jumping.

1.2 Restrictions

1.2.1 Geometric features

1.2.1.1 Ski length

According to the body weight/length height relationship ($BMI = \text{body weight} / \text{body } \text{length height}^2$ in kg/m^2). (see enclosure)

However, the maximum ski length is 145 % of the total body length height of the competitor based on a minimum BMI of 21 for Women and 21 for Men. For athletes with less than minimum BMI a grading table of 0,125 BMI will be applied.

Exception: For Youth competitions, the maximum ski length is limited to 140 % from the body length height only (no BMI formula will be applied).

1.2.1.2 Profile width (see enclosure)

The curvature from A through B to C indicates the shape of the ski side cut. This curvature must be equal on both sides and symmetrical to the ski centre line. As a maximum the line connection from A to B, as well as B to C should appear as a straight line.

Minimum width of the running surface at the point of balances 95 mm, maximum width 105 mm.

The edges must form a 90° angle to the running surface and the top surface along the entire length of the ski.

Rounded top-to-bottom edges must never be more than 2 mm.

The difference between the above-mentioned measurement of the width of the ski tip and the ski tail may not exceed 5 mm.

1.2.1.3 Contour, length and height of shovel

The ski tip may be individually modified as long as it remains symmetric and centred to the middle part and that the minimum distance to the surface of 40 mm is observed, when the ski is pushed to the surface at 57% of the ski length (whole surface of the ski must be placed on the flat surface).

Ski tip must be curved. The depth of the curve must be minimum 3.5 mm within 120 mm from the ski tip.

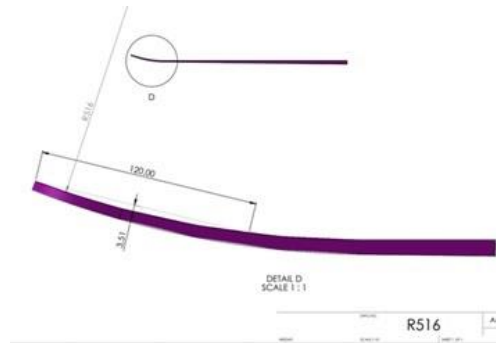

1.2.1.4 Contour of tail

According to the sketch (see page 26)

Maximum height 10 mm.

1.2.1.5 Running surface

Running surface must be flat and may have a fine base structure in a longitudinal direction. With the exception of the grooves, the entire ski base cannot have any additional shapes. There can be one or more grooves; however the total of the measured surface area of all the grooves may not exceed 50% of the minimal width of the ski. The width of a single groove may not exceed 10 mm. The base must be of a polyethylene material.

1.2.1.6 Top surface

The top surface of the ski must be smooth, flat and straight over the entire width of the ski. The ski must have an even and regular surface, free from perceptible projections, lumps or indentations.

1.2.2 Shape and Flexibility

Aerodynamic coverings on the tips, as well as fins in the form of stabilizers on any sides are not allowed. A design, which makes a desired aerodynamic flex possible during flight, is not allowed. Otherwise, there are no limitations with regard to rigidity in all grades of flex. The top surface of the ski must be smooth and flat.

1.2.3 Mass

A single non-mounted ski must have a minimum weight conforming to its length (the weight in kg results of the ski length in cm: e.g.

250 cm = 2,50 kg, 262 cm = 2,62 kg). Lead-weights used for balancing the centre of gravity are not considered (see 1.2.6.2). The weight of the ski can be measured with bindings (whole binding system – front and back part including ski wedges and screws). In this case, the weight of the ski must show the weight of the ski (minimum weight conforming to ski length) with added weight of the bindings of minimum ~~250~~ 200 grams.

1.2.4 Construction

1.2.4.1 Ski components

Torsion box: No limitations with regard to material and dimensions.

Edges: see 1.2.1.2.

1.2.5 Durability

The jumping ski must have screw retention strength of 1600 N in the area of the binding mounting.

1.2.6 Additional equipment

1.2.6.1 No additional equipment is permitted which

- a) makes use of foreign energy (e.g. heaters, chemical energy accumulators, electric batteries, mechanical aids, etc.).
- b) causes or intends to cause changes in the outer conditions of the competition to the disadvantage of fellow competitors (e.g. changes to piste or snow).
- c) increases the risk of injury to users or other persons, when used for the purpose it was intended for.

1.2.6.2 Additional weights

Additional weights for balancing the centre of gravity are permitted. If these are attached to the surface of the ski with scotch tape or similar the total surface of the tape cannot exceed 45 cm².

2. Jumping Ski Bindings

Safety bindings in Ski Jumping function as strain limiters. That is, these devices transfer specific demands occurring during skiing to an acceptable limit, and when this limit is overstepped, they release their firm hold on the ski.

Additional devices creating foreign energy of any kind as an aid to take-off are forbidden.

The complete binding system must be mounted so, that the Ski Jumping boots are fixed to the skis symmetrically, along the axis of the ski, and parallel to the running direction. Bindings must be flat mounted on the ski. All mounting screws of the front part of the binding must be located in the front of the lock part of the binding. After fixing the front part of the jumping boot into the front part of the binding it must stay fixed and horizontal to the top surface of the ski. The outline of the heel wedge of the shoe sole in its normal production form may not protrude over the side-walls of the jumping ski. Minimum weight of the whole binding system – front and back part including ski wedges and screw of the ski bindings is 250-200 grams.

The use of a safety strap connecting the boot with the binding/ski is mandatory, unless a binding with a locker system is used.

2.1 Binding wedges

Binding wedges are permitted to improve the in-run position. The entire height of the boot sole and binding wedge must not exceed 50 70 mm.

2.2 Mounting of the bindings

The binding must be mounted in such a way that maximum 57% of the entire ski length is used as the front part. Measured from the ski tip (with shovel curvature) to the shoe cap (leather part). (The 57% will be rounded up or down to full centimetres).

3. Ski stopper

Ski stopper is a mechanism that prevents the ski from sliding down/away and lowers its speed when the boot is released from the binding. The use of ski stopper is mandatory in all FIS competitions (from winter 2023-24).

3. Ski Jumping Boots

3.1.1 Size and form

The boot size and form must equal the foot length and form. Maximum tolerance for boot size measurement (inside to outside) is + 2 cm.

3.1.2 Reshaping

Reshaping the boots in order to attain more aerodynamic features is not allowed.

3.1.3 Thickness of the sole

The boot sole may not exceed ~~40~~ 45 mm measured from inside to outside at the lowest point of the heel.

The entire height of the boot sole and binding wedge must not exceed 50 ~~70~~ mm.

3.1.4 Angle of the rear part

Lean angle of the rear part of the boot must not be under 65 degrees measured inside.

3.1.5 Back part

Thickness of the back part of the boot ~~at the highest edge~~ must not exceed ~~30~~ 80 mm ~~including the wedges if these are worn. Towards the heel the design of the rear part of the boot must be wedge shaped.~~ Thickness of the sides must be equal with a maximum thickness of 15 mm. ~~Maximum circumferences around the ankle joint position (12 above bottom part of the boots) must not exceed 45 cm.~~

3.2 Shields/spoilers

Carbon shields (spoilers) around the rear part of the boot are allowed, however, they must be attached to the boot surface over its entire area, must not extend beyond the surface of the boot and must be mounted symmetrically. If the spoiler does not cover the entire area, it must be mounted symmetrically.

These shall be mounted to the surface of the boot in such a way that no fixation of the suit to the boot/shield is possible.

3.3 Wedges

Wedges inside athlete's boots might be worn during the jump. Wedges must be symmetric. The following maximum sizes are allowed - back part: ~~3.5-5~~ cm; side: 1.5 cm on each side; front part: 0.5 cm. Wedge opening might only be positioned in its central front part. Opening on either side is not allowed. The upper edge of wedges must be placed **lowest** on the same level as that of the upper edge of jumping boots. The wedges must be placed inside the boots symmetrically (rotating wedges inside the boots is not allowed).

~~Total thickness of the rear part of the boot including the wedges must not exceed 80 mm. In their size and shape the outside of the boots must conform FIS measurement and control system. When inner boots are used, the suit must be fixed to the inner part.~~

4. Ski Jumping Suits

All portions of the ski jumping suit must be made of the same material (see 4.2) and must show the same air permeability from the outside in and from the inside out.

The suit must close by means of a zipper placed at the centre of the front. The closed zipper strap must exceed the collar end with 1,5 to 5 cm. The maximum zip length is allowed to end at least 10 cm before the cross part of the crotch. The zip must end minimum 5 cm below the waist seam of the suit. The width of this zipper may not exceed 15 mm. During the jump the zipper must be completely closed.

Collar must be round shaped. Height difference between the front and the back of the collar must be minimum 1 cm (while front part must always be lower) and may not exceed 5 cm (X1 and X2).

The design of the suit (seams) must conform to the image "Ski Jumping Suits" in the enclosure.

The suit must be close-fitting in any part of the body. The measured circumference of any unstretched part of the suit must not exceed the respective body measurement. It is not allowed to fix the sleeves of the suit to the gloves.

Exceptions are:

- to accommodate the fit of the suit around the boot with a maximum tolerance of 10 cm. This tolerance may start from the close-fitted part below the knee with a transition to the bottom hem of the leg panel.

Additional restrictions:

- Marking of the suit (for measuring and control) is allowed.
- The thickness of all parts of the suit must be the same.
- No additional chemical (gaseous, liquid or solid) or mechanical treatment of the material or suits is allowed.
- Outer tucks and darts, folds and padding are not allowed.
 - Only one fixed (non-adjustable) strap per leg is allowed for fixing the suit around the ski boot. The strap is of one continuous piece and without clips, buckles or other means of fastening multiple pieces of material. The fixation of either strap must be made at the hem of the suit in the middle of the posterior and anterior seam of the leg panels (see the illustration - mark S). Leg hem must be cut horizontally straight across the width of the strap at the same height. The leg hem must not exceed in length the lower sole of the ski jumping boot. The width of the strap must be min 2 and max 4 cm. The width of this part of the leg must not exceed respective strap width. The strap must be placed at 90 degrees angle to the boot sole and in line with the leg panel seams. symmetrically around the boot during the jump. The leg of the suit cannot be fixed to the boot in any other way than with the strap.

- Length of the sleeve must reach the wrist joint. The lower hem of the sleeve is cut evenly and has no integrated hole for fingers. The edge of the sleeve must be cut at 90 degrees to the side-line of the seams.
- All hems must be sewn by a singular piece and the entire piece must have the same physical material characteristics.

Standardized measuring control points:

- Anterior arm length (see the illustration - mark AL) is measured from end of the sleeve in a straight line to the intersection of the seams at the armpit. Measured length must be no greater than the length of the arm and no shorter than a maximum tolerance of -4 cm. The intersection of seams at the armpit must be the lowest point. The shape of the cut in the armpit must be rounded.
- Anterior crotch length (see the illustration - mark SL) is measured from the intersection of the seams at the crotch of the suit (see the illustration - mark SX) following the anterior seam in a straight line to the hem of the leg part of the suit. Measured length of the suit (leg) must be no shorter than the measured crotch height.

During crotch control, measured crotch height must be no shorter than the measured crotch length of the athlete +3 cm.

Number of parts of the material of which the suit consists of is:

- One part for each sleeve (3). The sleeve must be joined to the main part of the suit and must reach the wrist joint. In addition, when the arm is extended from the torso, the anterior seam of the sleeve must be aligned with the torso seam.
- Three parts for the torso (upper body above the waist seam): left and right front panels (1) and back part (4). Starting from the armpit down to the waist seam, the front and back part must be equal.
- 2 for each leg (under the waist seam): the front leg panels (2) and the back leg panels (5). Starting from the waist seam, the size of the panels must be equal front and back. The alignment of the posterior and anterior seams is entered along the length of the leg. The front and back crotch seams must connect with the anterior leg seams at the lowest point of the crotch (see the illustration - mark SX).
- Zipper, elastics and strings for the attachments do not count as a separate part of the suit.
- The waist seam must be placed in relationship to the body within 5 cm above and below the hip bone (narrow part of the waist). The seam must go around the torso horizontally at the same height.
- The seam connecting the upper front and side panel must align vertically with the seam of the leg panels from the armpit to the posterior ankle bone.
- The bottom hem of the leg panels may be altered to accommodate the fixing of the binding at the heel of the boot.
- Seams may only exist in order to join the portions of the suit. Seams must be inside the suit. It is not allowed to edge-stitch (sew) the ends of the material; it is not allowed to join (sew) the maximum seam of 10 mm (material behind the seam to the edge). All seams must be straight or formed differently only to fit the form of the body. Any additional seams or transformation of the seams, any

strings, rods, folds, tapes, etc., inside or outside the suit in order to attain greater volume or more aerodynamic features is not allowed (the same for the underwear).

- The enclosed suit illustrations are the determining bases for these written rules. Exception for Youth competitions: no limit for number of parts and cutting of the suits.
- The outside width of the legs cannot exceed the outside width of the shoulders.
- The suit must be measurable at each and every place. For measurement, the suit surface must be stretched, flat and without any folds.
- Crotch – At the height of 2 cm, the front seam must protrude maximum 3 cm to the front from the intersection of the crotch seams, while back seam must protrude maximum 5 cm to the back from the intersection of the crotch seams according to the below template, while the suit is placed inside out. Intersection of the crotch seams must always be the lowest part. The seams from the intersection at crotch towards the waist seam must go with one single curve and straight.
- The leg of the suit must be cut and sewn along the axis of the leg.

Additional specifications for the women's Ski Jumping suit

Number of parts of the material of which the suit consists of is:

- 5 parts for the upper body (1, 3, and 5), plus 2 parts (4 and 6) for shoulders.
The waist seam must go around the torso horizontally at the same height and must be placed at the part of the body with the smallest circumferences.
- Two parts for each sleeve including shoulder: front part of the sleeve (4) and back part of the sleeve (6). Each sleeve starts from the neck opening and extends over the shoulder maximally to the wrist joint. Starting from the armpit down the size of the panels must be equal front and back. The alignment of the posterior seam must be centred along the length of the sleeve and parallel to the torso seam. In addition, when the arm is extended from the torso, the anterior seam of the sleeve must be aligned with the torso seam. The intersection of seams at the armpit must be the lowest point. The shape of the cut in the armpit must be rounded.
- the lower part of the suit, below waist seam is identical with the men's cut (2 and 7)
- upper front parts (1)

The upper area of front part 1 must have a width of at least 10 cm. The front seam between the side part 1 and 3 must run over the middle part of the breast.

4.1 Material, fabric

The structure of the surface of the material and the composition of the material for all parts of the suit must be the same. The only exceptions are different colours of the same material.

The thickness of the suit may not exceed 6.0 mm, nor be less than 4.0 mm. Construction of the ski jumping suit is a five-layer laminated fabric and consists of:

- outer fabric/ first layer

- foam
- elastic membrane
- foam
- lining fabric

The components are laminated together by either a hot-melt process or flame laminated, where 4 acts are necessary to laminate the fabric.

The controlled air permeability of 40 l/m²/sec. (FIS Rules) is reached by perforation and guarantees a constant value.

Outer fabric / first layer

The outer fabric for the ski jumper laminate is a bi-elastic warp-knit fabric, called Charmeuse (pattern notation). This material is produced on a 2-thread system warp knitting machine.

Material:

81 % Polyamid gloss dtex 44f12

19 % Elasthane (Lycra) dtex 44f1

Weight:

180/190 g/m² approx.

Elasticity:

Length 150-160%

Width approx. 85-95%

Finishing:

The quality is dyed in a classical piece dyeing method (acid dyestuff). Beside the dyestuff and eventual dyeing assistant there is no use of other chemical stuff allowed, which would change the characteristics of the surface.

Material has two different sides:

- a) Lengthwise stripe "rip fabric (even side)"
- b) Transverse thread connection, called satin-side

The satin side is the visible outside of the jumping suit. The satin side must be chinsed. There are no other additional treatments like chemical or mechanic surface changes allowed (for example by aluminium steam, foil application, shaping or others).

Lining fabric

Lining fabric is identical with the outer fabric (material and weight) but only white.

Inside fabric / foam and elastic membrane

The inner life of the material is a three-layer laminate built up of a two 2,1 mm foam layers (volumetric weight ca. 55g) and with an elastic membrane in the middle. This laminate is perforated to reach the defined air permeability.

4.2 Air permeability of the suit material

The material of a jumping suit must show a minimum air permeability which is the same from the outside in and from the inside out.

Minimum air permeability is established as follows:

The unstretched fabric must show a medium air permeability of a minimum of 40 litres per m²/sec with 10 mm water pressure.

~~This value is compulsory at the time of distribution by the manufacturer that means at the moment of plumbing.~~

At controls in competitions, it must not be less than 40 litres.

The maximum difference between various parts during the control must not exceed 12 litres.

4.3 Underwear

The underwear is consisting of two parts (shirt and pants), made of elastic material. No zipper, buttons, Velcro or similar on the T-shirt are allowed.

It is not allowed to attach or fix the underwear to any part of the body or the suit (straps, hooks, tapes, or other fixing or helping material, etc.). No fixations (i.e. integrated holes for fingers) are allowed. No form of a hood is allowed.

The arm sleeve must end before the elbow. The leg of the pants must end before the knee. Overlapping of the stockings/socks and the pants is not allowed.

The thickness of the underwear must not exceed 5,0 mm (cumulative - all layers and parts of the underwear together).

Air permeability of the underwear must exceed 60 l/m². The size, fit and form of underwear must conform the size and shape of the body.

4.4 Examination of materials, suits

The guidelines for minimum air permeability established by the FIS Control Procedures/Equipment Working Group in collaboration with the Federal Institute for Materials Control are valid.

Multi-layered materials are accordingly permitted for ski jumping suits, as long as they conform to the technical specifications and air permeability requirements and all portions of the suit are made from the same material.

5. Crash Helmets

The use of crash helmets is compulsory for all events. The shape of the helmet must conform to the shape of the head. The distance measured at any point between the outside surface of the helmet and the head shall not exceed 7 cm.

It is not allowed to attach anything to the helmet surface incl. cameras and holding/fixing systems, unless approved by FIS Race Director / Coordinator. The crash helmets used for international FIS competitions shall comply with the standards applicable for crash helmets for Alpine ski competitions (crash helmets to be used in Ski Jumping).

Compliance with the standards is to be attested by the corresponding specific standardised conformity label affixed in a non-removable way at the back of the helmet in a location which is and shall remain visible. The label shall in particular not be covered by the goggle strap. The conformity label (Label "RH2013") confirming compliance with the standard applicable to helmets to be used for international FIS competitions is shown in attachment. The labels affixed by manufacturers shall comply with the specifications set forth in the enclosure (page 3 7).

6. Ski Goggles

Ski goggles are devices protecting the eyes against weather and rays with optically correct lenses. Their aim is to guarantee good, contrast-free visibility in all weather conditions. The use of goggles is mandatory recommended.

7. Ski Gloves

Gloves offer protective covering against weather and external forces. The use of gloves is compulsory for all events.

The glove size must correspond to the hand size. Thickness of the material cannot exceed 5 mm.

Mittens are not allowed. Only gloves with fingers (for all fingers) are allowed. The gloves may not be fin shaped.

It is not allowed to fix the sleeve/suit around the gloves in anyway.

The seams of the gloves must be inside the gloves.

8. Back Protector

8.1 Definition

The back protector is an additional item of equipment, which protects the athlete's back against external forces. It has to be worn on the back only.

8.2 Specifications of the back protector

The material of the protector consists of visco elastic soft foam with outstanding shock absorption values according to EC EN1621-2:2014 with given form. The back protector must adapt to the anatomical bend of the athlete's spine and lie flat against the body in upright position. The maximum size and thickness must conform to the performance level 1 or 2. The thickness reduces at the edges of the back protector. Designs with the view to improve the aerodynamic efficiency are forbidden. The back protector must be worn in an adequate pocket in the shirt and is removable. The pocket is an integrated part of the shirt.

Sizes of back protectors:

S for body size 120 - 140 cm

M 135 - 155 cm

ML 150 - 170 cm

L 165 - 185 cm

XL 180 - 205 cm

D. Bibs

- Nordic: Cross-Country / Ski Jumping

Examples: See enclosure.

1. FIS Specifications for Cross-Country Starting Bibs

1.1 Advertising

According to ["FIS Advertising Rules"](#)

1.2 Numbers

According to ["FIS Advertising Rules"](#)

1.3 Assignment

Starting bibs must be assigned as follows and must be cut in such a way that the skier's shoulders are allowed free movement:

Women size: without elastic band

Men's size: without elastic band

1.4 Fabric, material

T-shirt starting bibs in smooth material quality 100% Polyester / Interlock or 100 % polyester knitwear (meshed or non-meshed).

1.5 Elasticity (stretch)

Meshed starting bibs: measured on a piece of fabric 10 cm wide:

Stretch ability in the width 18,5 cm

None meshed starting bibs: measured on a piece of fabric 10 cm wide:

Stretch ability in the width: 24 cm (see enclosure)

2. FIS Specifications for Ski Jumping Starting Bibs

2.1 Advertising

According to ["FIS Advertising Rules"](#)

2.2 Numbers

According to ["FIS Advertising Rules"](#)

2.3 Assignment

Starting bibs are assigned to the men in men's sizes.

2.4 Fabric, material

T-Shirt starting bibs 100 % Polyester with an air permeability of 40 litres per m²/sec under 10 mm of water pressure.

2.5 Elasticity (stretch)

Measured on a piece of fabric 10 cm wide:

Stretch ability in the width 24 cm.

2.6 Seams, sewing

Side seams: material is sewn together, hemmed and stitched - overlook.

Neckline and armholes are trimmed with edging and double-stitched.

Waistband with 2 cm wide seam, double-stitched (see enclosure).

Ski Jumping Men

Without elastic band

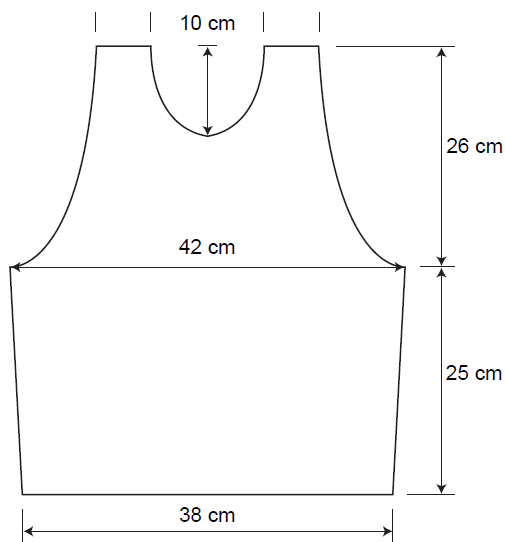

Ski Jumping Women

Without elastic band

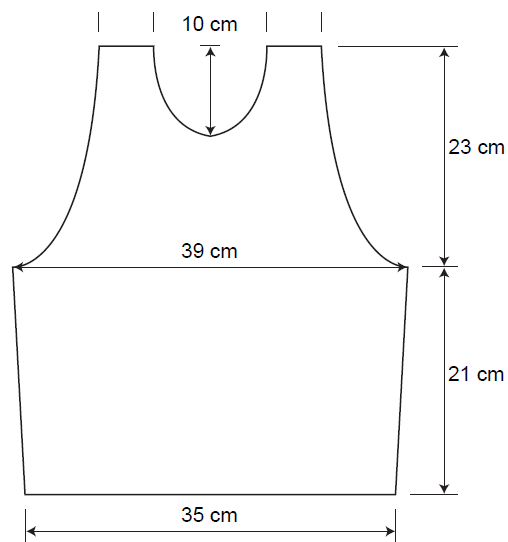

Cross-Country Men

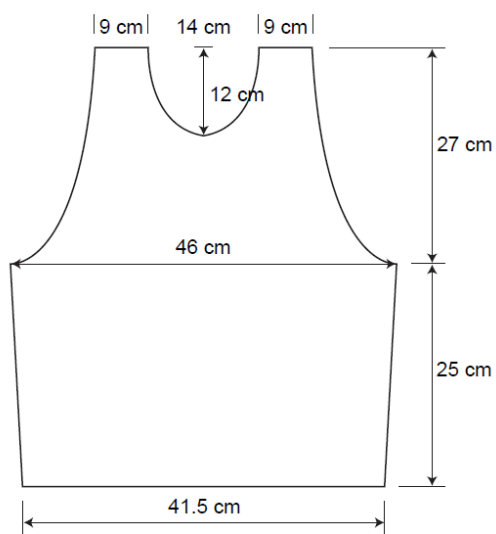

Cross-Country Women

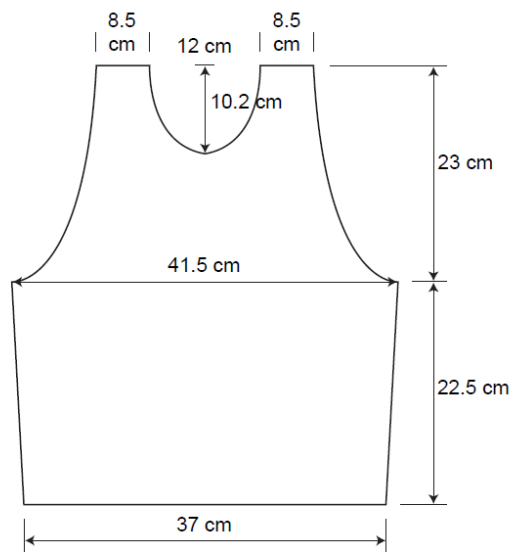

Measurement table for mounting of Ski Jumping Bindings

Masstabelle für Montage der Skisprungbindung						
Measuring table for mounting of jumping bindings						
ab Saison 2010/2011 - as from Season 2010/2011						
Body Height Körpergröße	Ski length 145% Skilänge 145%	Front ski = 57% Vorderski = 57%		Body Height Körpergröße	Ski length 145% Skilänge 145%	Front ski = 57% Vorderski = 57%
cm	cm	cm		cm	cm	cm
140	203	116		155	225	128
141	204	116		156	226	129
	205	117			227	129
142	206	117		157	228	130
143	207	118		158	229	131
	208	119			230	131
144	209	119		159	231	132
145	210	120		160	232	132
	211	120		161	233	133
146	212	121			234	133
147	213	121		162	235	134
	214	122		163	236	135
148	215	123			237	135
149	216	123		164	238	136
	217	124		165	239	136
150	218	124			240	137
151	219	125		166	241	137
152	220	125		167	242	138
	221	126			243	139
153	222	127		168	244	139
154	223	127		169	245	140
	224	128				

Masstabelle für Montage der Skisprungbindung						
Measuring table for mounting of jumping bindings						
ab Saison 2010/2011 - as from Season 2010/2011						
Body Height Körpergröße	Ski length 145% Skilänge 145%	Front ski = 57% Vorderski = 57%		Body Height Körpergröße	Ski length 145% Skilänge 145%	Front ski = 57% Vorderski = 57%
cm	cm	cm		cm	cm	cm
	246	140		185	268	153
170	247	141			269	153
171	248	141		186	270	154
172	249	142		187	271	154
	250	143			272	155
173	251	143		188	273	156
174	252	144		189	274	156
	253	144			275	157
175	254	145		190	276	157
176	255	145		191	277	158
	256	146		192	278	158
177	257	146			279	159
178	258	147		193	280	160
	259	148		194	281	160
179	260	148			282	161
180	261	149		195	283	161
181	262	149		196	284	162
	263	150			285	162
182	264	150		197	286	163
183	265	151		198	287	164
	266	152			288	164
184	267	152		199	289	165
				200	290	165

Measurement table for mounting of Ski Jumping Bindings

Jugend Cup - Masstabelle für Skilänge und Bindungsmontage					
Youth Cup - Measuring table for Ski length and mounting of the bindings					
ab Saison 2010/2011 - as from Season 2010/2011					
Body Height Körpergröße	Ski length = 140% Skilänge = 140%	Front ski = 57% Vorderski = 57%	Body Height Körpergröße	Ski length = 140% Skilänge = 140%	Front ski = 57% Vorderski = 57%
cm	cm	cm	cm	cm	cm
125	175	100	156	218	124
126	176	100		219	125
	177	101	157	220	125
127	178	101	158	221	126
128	179	102		222	127
	180	103	159	223	127
129	181	103	160	224	128
130	182	104	161	225	128
131	183	104		226	129
	184	105	162	227	129
132	185	105	163	228	130
133	186	106		229	131
	187	107	164	230	131
134	188	107	165	231	132
135	189	108	166	232	132
136	190	108		233	133
	191	109	167	234	133
137	192	109	168	235	134
138	193	110		236	135
	194	111	169	237	135
139	195	111	170	238	136
140	196	112	171	239	136
141	197	112		240	137
	198	113	172	241	137
142	199	113	173	242	138
143	200	114		243	139
	201	115	174	244	139
144	202	115	175	245	140
145	203	116	176	246	140
146	204	116		247	141

	205	117	177	248	141
147	206	117	178	249	142
148	207	118		250	143
	208	119	179	251	143
149	209	119	180	252	144
150	210	120	181	253	144
151	211	120		254	145
	212	121	182	255	145
152	213	121	183	256	146
153	214	122		257	146
	215	123	184	258	147
154	216	123	185	259	148
155	217	124	186	260	148

Jumping Skis

Article 1.2.1.2: Precision of the Profile Width

L	Ski length
a	max. width at front portion = 115 mm
b	max. width at 57% of front portion (f) = 105 mm
c	max. width at tail portion = 115 mm
d	max. length between tip and begin of sidecut = 300 mm
e	max. length between tail and begin of sidecut = 150 mm
f	control point of b

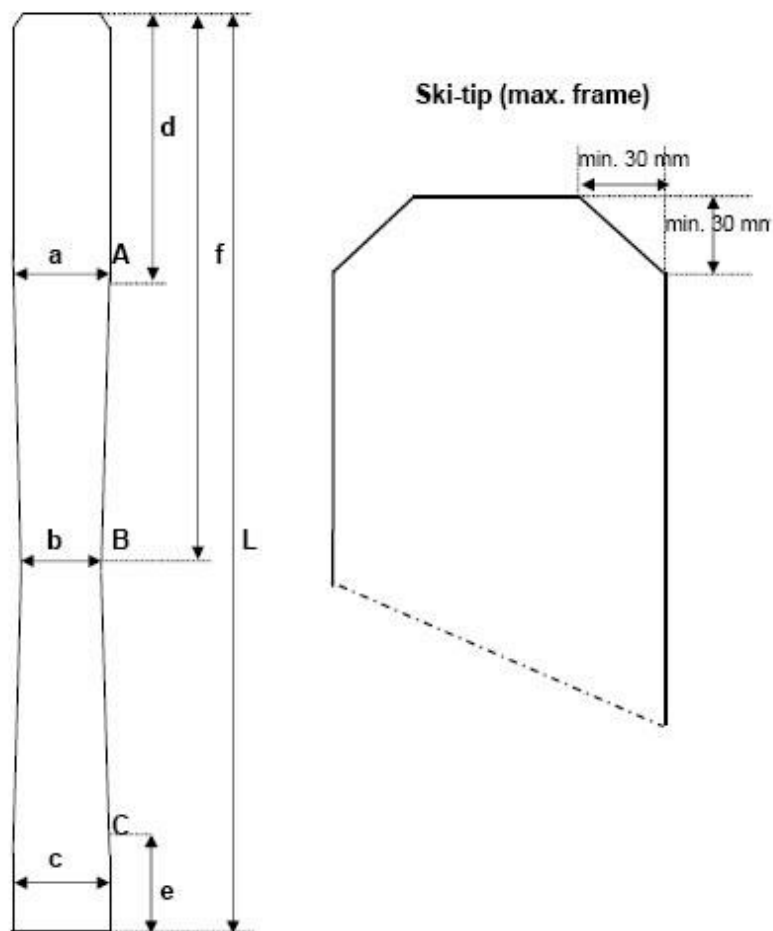

Label attesting conformity with FIS specifications for helmets.



Minimum Width : **10 Mm**

Minimum height : **15 Mm**

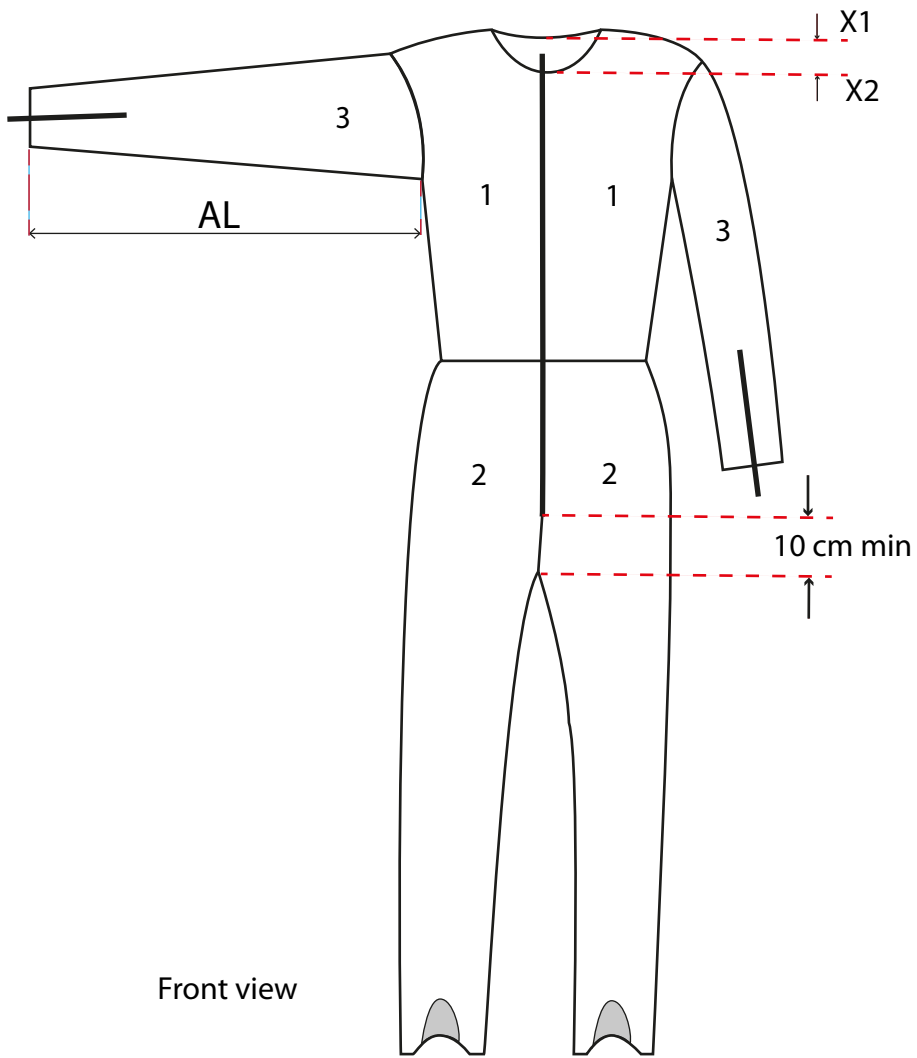

Front view

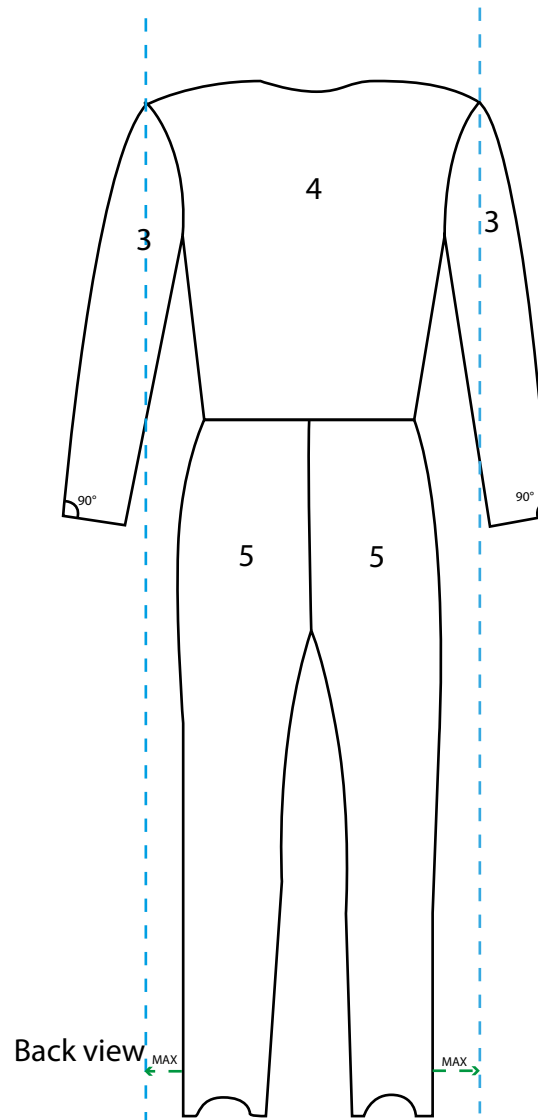

Back view

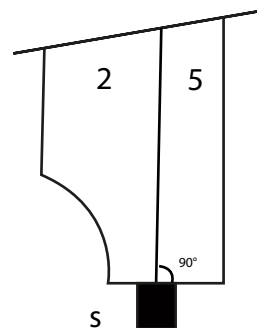
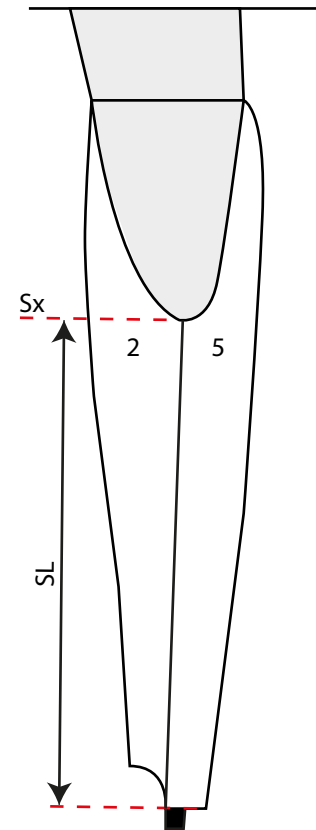

Jumping Suit MEN
 Version 1.1
 12. October 2022
 created by: H.Nilgen
 released by: A.Baczowska

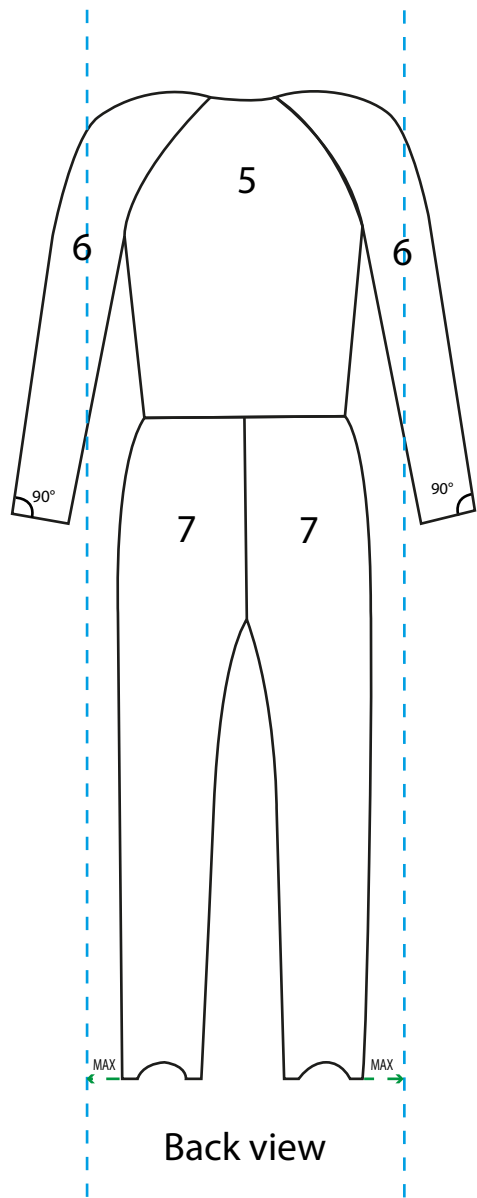

Back view

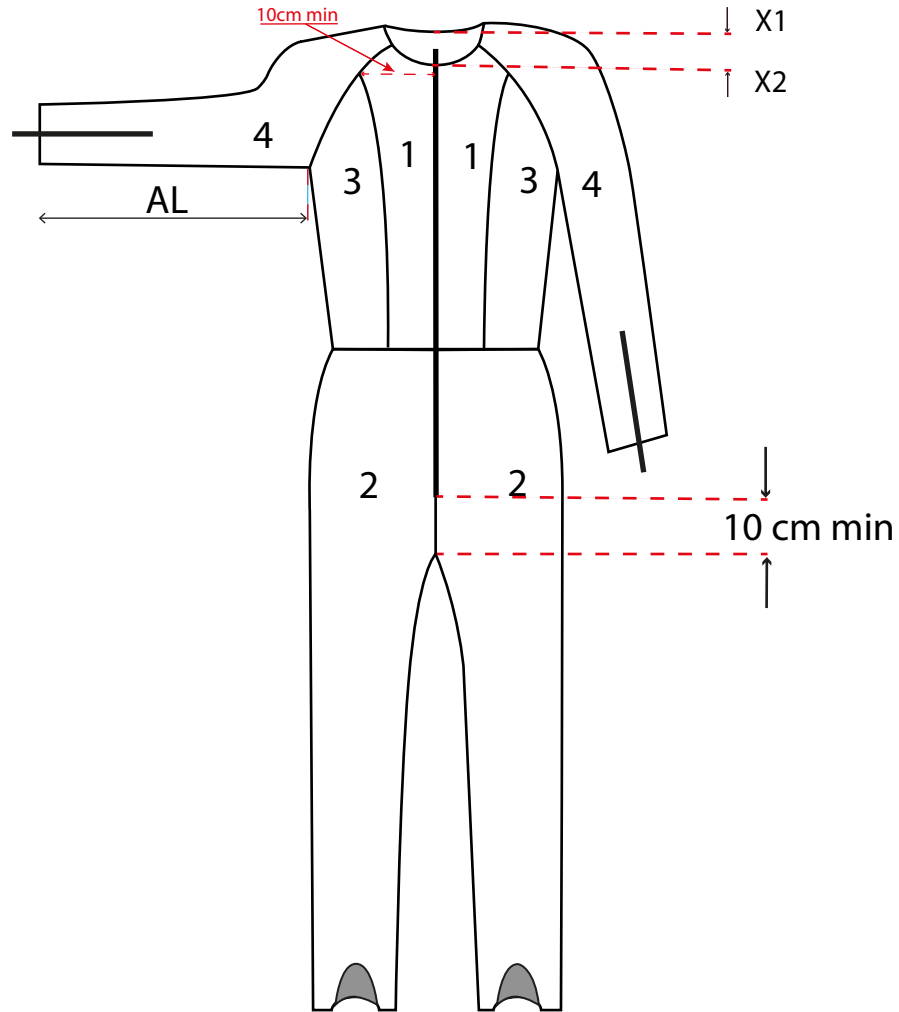

Front view

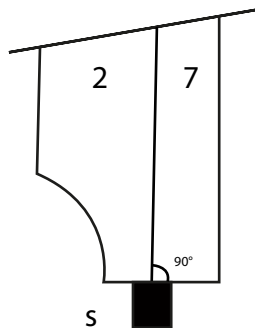
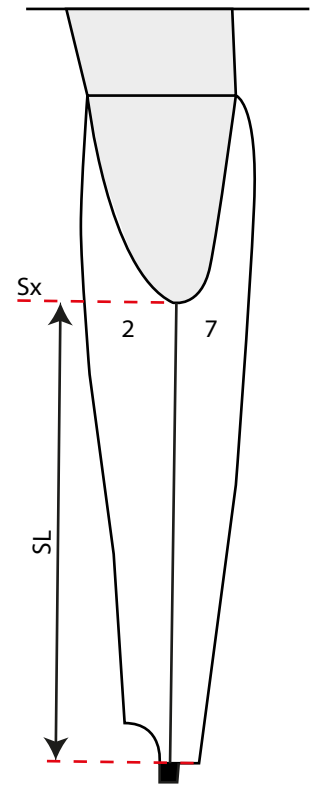

Jumping Suit WOMEN
 Version 1.1
 12. October 2022
 created by: H.Nilgen
 released by: A.Baczowska

Row #	22		23		24		25		26		27		28		29		30		31		32		33		34		35		36		37		38		39		40		41	
	kg	cm	kg	cm	kg	cm	kg	cm	kg	cm	kg	cm	kg	cm	kg	cm	kg	cm	kg	cm	kg	cm	kg	cm	kg	cm	kg	cm	kg	cm	kg	cm	kg	cm	kg	cm	kg	cm	kg	cm
	16,375	134.5	16,250	134.0	16,125	133.5	16,000	133.0	15,875	132.5	15,750	132.0	15,625	131.5	15,500	131.0	15,375	130.5	15,250	130.0	15,125	129.5	15,000	129.0	14,875	128.5	14,750	128.0	14,625	127.5	14,500	127.0	14,375	126.5	14,250	126.0	14,125	125.5	14,000	125.0
140	36.0	188	36.8	188	35.5	187	35.3	186	35.0	186	34.8	185	34.5	184	34.3	183	34.1	183	33.8	182	33.6	181	33.3	181	33.1	180	32.8	179	32.6	179	32.3	178	32.1	177	31.9	176	31.6	176	31.4	175
141	36.5	190	36.3	189	36.0	188	35.8	188	35.5	187	35.3	186	35.0	185	34.8	185	34.5	184	34.3	183	34.0	183	33.8	182	33.5	181	33.2	180	33.0	179	32.7	178	32.6	177	32.3	176	32.1	177	31.8	176
142	37.1	191	36.8	190	36.5	190	36.3	189	36.0	188	35.8	187	35.5	187	35.3	186	35.0	185	34.8	185	34.5	184	34.3	183	34.0	182	33.8	182	33.5	181	33.3	180	33.0	180	32.8	179	32.5	178	32.3	178
143	37.6	192	37.3	192	37.1	191	36.8	190	36.6	189	36.3	189	36.0	188	35.8	187	35.5	187	35.3	186	35.0	185	34.8	184	34.5	184	34.3	183	34.0	182	33.7	182	33.5	181	33.2	180	33.0	179	32.7	179
144	38.1	194	37.8	193	37.6	192	37.3	192	37.1	191	36.8	190	36.5	189	36.3	189	36.0	188	35.8	187	35.5	186	35.3	186	35.0	185	34.7	184	34.5	184	34.2	183	34.0	182	33.7	181	33.4	181	33.2	180
145	38.6	195	38.4	194	38.1	194	37.8	193	37.6	192	37.3	191	37.1	191	36.8	190	36.5	189	36.3	189	36.0	188	35.7	187	35.5	186	35.2	186	35.0	185	34.7	184	34.4	183	34.2	183	33.9	182	33.6	181
146	39.2	196	38.9	196	38.6	195	38.4	194	38.1	193	37.8	193	37.6	192	37.3	191	37.0	191	36.8	190	36.5	189	36.2	188	36.0	188	35.7	187	35.4	186	35.2	185	34.9	185	34.6	184	34.4	183	34.1	183
147	39.7	198	39.4	197	39.2	196	38.9	196	38.6	195	38.4	194	38.1	193	37.8	193	37.5	192	37.3	191	37.0	190	36.7	190	36.5	189	36.2	188	35.9	187	35.7	187	35.4	186	35.1	185	34.8	184	34.6	184
148	40.2	199	40.0	198	39.7	198	39.4	197	39.2	196	38.9	195	38.6	195	38.3	194	38.1	193	37.8	192	37.5	192	37.2	191	37.0	190	36.7	189	36.4	189	36.1	188	35.9	187	35.6	186	35.3	186	35.0	185
149	40.8	200	40.5	200	40.2	199	40.0	198	39.7	197	39.4	197	39.1	196	38.9	195	38.6	194	38.3	194	38.0	193	37.7	192	37.5	191	37.2	191	36.9	190	36.6	189	36.4	188	36.1	188	35.8	187	35.5	186
150	41.3	202	41.1	201	40.8	200	40.5	200	40.2	199	39.9	198	39.7	197	39.4	197	39.1	196	38.8	195	38.5	194	38.3	194	38.0	193	37.7	192	37.4	191	37.1	191	36.8	190	36.6	189	36.3	188	36.0	188
151	41.9	203	41.6	202	41.3	202	41.0	201	40.8	200	40.5	199	40.2	199	39.9	198	39.6	197	39.3	196	39.0	196	38.8	195	38.5	194	38.2	193	37.9	193	37.6	192	37.3	191	37.1	190	36.8	189	36.5	189
152	42.5	204	42.2	204	41.9	203	41.6	202	41.3	201	41.0	201	40.7	200	40.4	199	40.1	198	39.9	198	39.6	197	39.3	196	39.0	195	38.7	195	38.4	194	38.1	193	37.8	192	37.5	192	37.3	191	37.0	190
153	43.0	206	42.7	205	42.4	204	42.1	203	41.8	203	41.6	202	41.3	201	41.0	200	40.7	200	40.4	199	40.1	198	39.8	197	39.5	197	39.2	196	38.9	195	38.6	194	38.3	194	38.0	193	37.7	192	37.5	191
154	43.6	207	43.3	206	43.0	206	42.7	205	42.4	204	42.1	203	41.8	203	41.5	202	41.2	201	40.9	200	40.6	199	40.3	199	40.0	198	39.7	197	39.4	196	39.1	196	38.8	195	38.5	194	38.2	193	37.9	193
155	44.1	208	43.8	208	43.5	207	43.2	206	42.9	205	42.6	205	42.3	204	42.0	203	41.7	202	41.4	202	41.1	201	40.8	200	40.5	199	40.2	198	39.9	198	39.6	197	39.3	196	39.0	195	38.7	195	38.4	194
156	44.7	210	44.4	209	44.1	208	43.8	207	43.5	207	43.2	206	42.9	205	42.6	204	42.3	204	42.0	203	41.7	202	41.4	201	41.1	200	40.8	200	40.5	199	40.2	198	39.9	197	39.5	197	39.2	196	38.9	195
157	45.3	211	45.0	210	44.7	210	44.4	209	44.1	208	43.8	207	43.4	206	43.1	206	42.8	205	42.5	204	42.2	203	41.9	203	41.6	202	41.3	201	41.0	200	40.7	199	40.4	199	40.1	198	39.7	197	39.4	196
158	45.9	213	45.6	212	45.2	211	44.9	210	44.6	209	44.3	209	44.0	208	43.7	207	43.4	206	43.1	205	42.8	205	42.4	204	42.1	203	41.8	202	41.5	201	41.2	201	40.9	200	40.6	199	40.3	198	39.9	198
159	46.5	214	46.1	213	45.8	212	45.5	211	45.2	211	44.9	210	44.6	209	44.2	208	43.9	207	43.6	207	43.3	206	43.0	205	42.7	204	42.3	204	42.0	203	41.7	202	41.4	201	41.1	200	40.8	200	40.4	199
160	47.0	215	46.7	214	46.4	214	46.1	213	45.8	212	45.4	211	45.1	210	44.8	210	44.5	209	44.2	208	43.8	207	43.5	206	43.2	206	42.9	205	42.6	204	42.2	203	41.9	202	41.6	202	41.3	201	41.0	200
161	47.6	217	47.3	216	47.0	215	46.7	214	46.3	213	46.0	213	45.7	212	45.4	211	45.0	210	44.7	209	44.4	208	44.1	208	43.7	207	43.4	206	43.1	205	42.8	204	42.4	204	42.1	203	41.8	202	41.5	201
162	48.2	218	47.9	217	47.6	216	47.2	215	46.9	214	46.6	214	46.3	213	45.9	212	45.6	211	45.3	211	44.9	210	44.6	209	44.3	208	44.0	207	43.6	207	43.3	206	43.0	205	42.6	204	42.3	203	42.0	203
163	48.8	219	48.5	218	48.2	218	47.8	217	47.5	216	47.2	215	46.8	214	46.5	214	46.2	213	45.8	212	45.5	211	45.2	210	44.8	209	44.5	209	44.2	208	43.8	207	43.5	206	43.2	205	42.8	205	42.5	204
164	49.4	221	49.1	220	48.7	219	48.4	218	48.1	217	47.7	216	47.4	216	47.1	215	46.7	214	46.4	213	46.1	212	45.7	212	45.4	211	45.1	210	44.7	209	44.4	208	44.0	207	43.7	207	43.4	206	43.0	205
165	50.0	222	49.7	221	49.3	220	49.0	219	48.7	219	48.3	218	48.0	217	47.6	216	47.3	215	47.0	215	46.6	214	46.3	213	45.9	212	45.6	211	45.3	210	44.9	210	44.6	209	44.2	208	43.9	207	43.6	206
166	50.6	223	50.3	222	49.9	222	49.6	221	49.3	220	48.9	219	48.6	218	48.2	217	47.9	217	47.5	216	47.2	215	46.8	214	46.5	213	46.2	212	45.8	212	45.5	211	45.1	210	44.8	209	44.4	208	44.1	208
167	51.2	225	50.9	224	50.5	223	50.2	222	49.9	221	49.5	220	49.2	220	48.8	219	48.5	218	48.1	217	47.8	216	47.4	215	47.1	215	46.7	214	46.4	213	46.0	212	45.7	211	45.3	210	45.0	210	44.6	209
168	51.9	226	51.5	225	51.2	224	50.8	223	50.5	223	50.1	222	49.7	221	49.4	220	49.0	219	48.7	218	48.3	218	48.0	217	47.6	216	47.3	215	46.9	214	46.6	213	46.2	213	45.9	212	45.5	211	45.2	210
169	52.5	227	52.1	226	51.8	226	51.4	225	51.1	224	50.7	223	50.3	222	50.0	221	49.6	221	49.3	220	48.9	219	48.6	218	48.2	217	47.8	216	47.5	215	47.1	215	46.8	214	46.4	213	46.1	212	45.7	211
170	53.1	229	52.7	228	52.4	227	52.0	226	51.7	225	51.3	224	50.9	224	50.6	223	50.2	222	49.9	221	49.5	220	49.1	219	48.8	218	48.4	218	48.0	217	47.7	216	47.3	215	47.0	214	46.6	213	46.2	213
171	53.7	230	53.4	229	53.0	228	52.6	227	52.3	227	51.9	226	51.5	225	51.2	224	50.8	223	50.4	222	50.1	221	49.7	219	49.3	220	48.9	219	48.6	218	48.2	217	47.9	216	47.5	215	47.2	215	46.8	214
172	54.3	231	54.0	230	53.6</																																			